

MODEL 163.113 /128 /136 /154 /157 /172 /174 /175

- 1 Side airbag
- 2 Mounting holes
- 3 Location hole
- 4 Locating tab

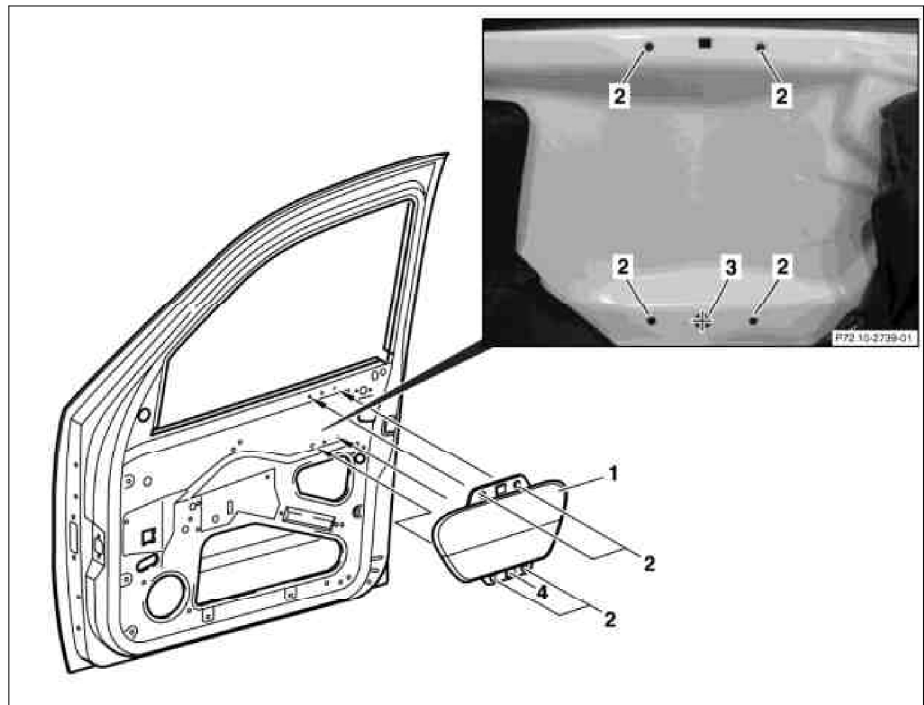

P72.10-2740-06

Operation no. of the operation texts or standard texts and flat rates

Range	Op. no.	Operation text	Flat rate	Acc. no.	Code
P	721680	Additional work to 1st door Location:.... replace transfer with components: Drill hole for side airbag	003 WU/0.3 h	---	---

1	Place side airbag (1) into position on door	i Use mounting holes (2) to align properly.	
2	Mark center of locating tab (4)		
3	Remove side airbag		
4	Drill 4 =10.5 mm hole (3) in door sheet metal at center location	! Ensure window glass will not be damaged by drilling.	
5	Smooth rough edges of hole		
6	Clean, prime, and paint hole		
7	Remove metal chips from bottom of door		

Parts ordering notes

Part no.	Designation	Quantity
000 986 06 50	Priming stick	1