

AR01.20-P-5014-02B	Remove/install cylinder head cover trim		
--------------------	---	--	--

Nm Crankcase ventilation, cylinder head cover

Number	Designation		Engine 612.961/ 962/967	Engine 612.963	Engine 612.965/ 966	Engine 612.990
BA01.20-P-1002-01A	Screw of trim panel of cylinder head cover to cylinder head cover	NM	10	10	10	8
BA01.20-P-1003-01A	Screw attaching cover panel to charge air distribution pipe	NM	10	10	10	-

1 Unscrew bolts (3, 4).

i **Installation:** Pay attention to tightening torques **Nm**.

2 Pull out trim panel (2) of charge air distribution pipe to the side.

ⓘ **Installation:** Insert shackles of trim panel (2) into the rubber mounts (5), so that the trim panel (2) is not damaged.

3 Take off trim panel (1) of cylinder head cover.

ⓘ **Installation:** Ensure the trim panel is correctly installed; ensure no lines are trapped.

4 Install in reverse sequence.

Illustrated on Engine 612.961

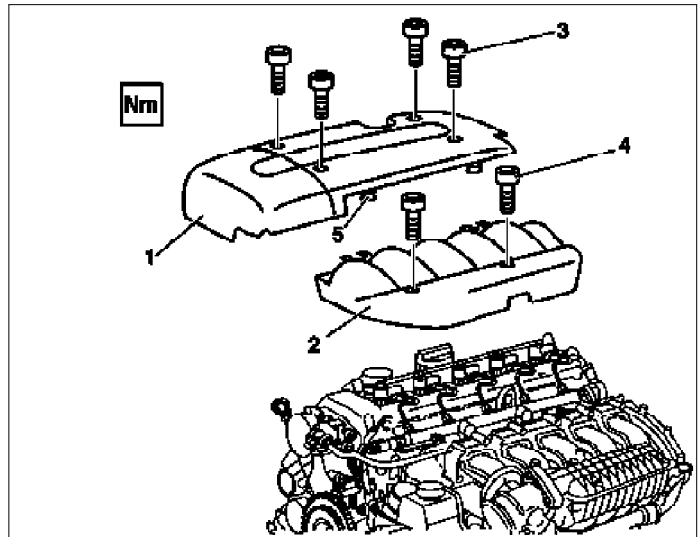

P01.20-2018-11